OPERATING INSTRUCTIONS

for

WUKO SEAM CLOSER

1003A

TABLE OF CONTENTS:

Safety Instructions	Page 3
General	
Technical Data	Page 4
Pre-Fabrication	Page 5
Before Operation	
Power supply voltage	Page 5
Sheet metal thickness of the seam lap	Page 5
Required free space between the jaws	Page 5
Adjusting the free space between the jaws	Page 6
Adjusting the hammer head	Page 6
Operation	
Closing on straight pieces	Page 7
Closing on round pieces	Page 7
Closing of small seam heights (3-6 mm)	Page 8
Maintenance	Page 8
Guarantee	Page 8
CE-Declaration of Conformity	Page 9
Spare parts list	
Spare parts for the head	Page 10
Spare parts for the electric drive	Page 11

SAFETY INSTRUCTIONS

WARNING! When using electric machines basic safety precautions should always be followed to reduce the risk of fire, electric shock and personal injury, including the following.

Read all these instructions before attempting to operate this product and save these instructions.

For safe operation:

1. Keep work area clean

Cluttered areas and benches invite injuries.

2. Consider work area environment

Don't expose machine to rain. Don't use machine in damp or wet locations. Keep work area well lit. Don't use machine in presence of flammable liquids or gases.

3. Guard against electric shock

Avoid body contact with grounded surfaces (e.g. pipes, radiators, refrigerators).

4. Keep children and visitors away

Do not let children contact machine or extension cable. All visitors should be kept away from work area.

5. Store idle tools

When not in use, tools should be stored in dry place, out of the reach of children.

6. Don't force tool

It will do the job better and safer at the rate for which it was designed.

7. Use right tool

Don't use tool for purposes not intended.

8. Dress properly

Sheets are very sharp-edged - wear protective gloves! Do not wear loose clothing or jewelry. They can be caught in moving parts. Gloves and non-skid footwear are recommended when working outdoors. Wear protective hair covering to contain long hair.

9. Don't abuse cable

Never carry tool by cable or yank it to disconnect it from socket. Keep cable from heat, oil and sharp edges.

10. Secure work

Use clamps or a vice to hold work. It's safer than using your hand and it frees both hands to operate the tool.

11. Don't overreach

Keep proper footing and balance at all times.

12. Maintain tools with care

Keep tools clean for better and safer performance. Follow instructions for changing accessories. Inspect cable periodically and, if damaged, have repaired by authorized service facility. Inspect extension cables periodically and replace if damaged. Keep handles dry, clean and free from oil and grease.

13. Disconnect tools

When not in use, before servicing, and when changing accessories.

14. Remove adjusting keys and wrenches

Form the habit of checking to see that keys and adjusting wrenches are removed from tool before turning it on.

15. Avoid unintentional starting

Don't carry plugged-in tool with finger on switch. Be sure switch is off when plugging in.

16. Outdoor use extension cords

When tool is used outdoors, use only extension cords intended for use outdoors and so marked.

17. Stay alert

Watch what you are doing. Use common sense. Do not operate machine when you are tired.

18. Check damaged parts

Before further use of the tool that is damaged it should be carefully checked to determine that it will operate properly and perform its intended function. Check for alignment of moving parts, binding of moving parts, breakage of parts, mounting, and any other conditions that may affect its operation. A machine part that is damaged should be properly repaired or replaced by an authorized service center unless otherwise indicated elsewhere in this instruction manual. Have defective switches replaced by an authorized service center. Do not use machine if it cannot be turned on and off by the switch.

19. Warning

The use of any other accessory or attachment other than recommended in this operating instruction may present a risk of personal injury, and could invalidate any guarantee.

20. Machine repairing by expert only

This electric machine is in accordance with the relevant safety rules. Repairing of electric machines may be carried out only by experts, otherwise it may cause considerable danger for the user.

Please read the operating instructions carefully in order to learn the operation and the various uses of your WUKO Seam Closer. Note the safety advises and retain the operating instructions!

GENERAL

1. WUKO SEAM CLOSER MODEL 1003A

WUKO Seam Closer consists of an electric drive and of a mechanical machine head.

The tool closes the lap of Z-seams (see sketch N° 1) on straight, as well as on round working pieces. The maximum sheet metal thickness of the lap is 1 mm at 400 N/mm².

The tool is normally equipped with jaws for seam height of 5...12 mm and is adjusted for a sheet metal thickness of 3 x 1 mm. Special jaws for a seam height of 3...6 mm and for a maximum sheet metal thickness of 0,75 mm are available as an option.

2. TECHNICAL DATA:

Electric drive (standard)	220-230V/50-60Hz/2,3A/500W
Seam height (standard)	5 - 12 mm
Maximum sheet metal thickness of seam lap	1 mm bei 400N/mm ²
Seam height (with spezial jaws)	3 - 6 mm
Maximum sheet metal thickness (for small seam heights)	0,75 mm bei 400N/mm ²
Vibration/Noise level	
Vibration/Acceleration	
according to EN 28662-1 and EN 50144	$a_{vhw} = 5.0 \text{ m/s}^2$
Typical noise level according to EN50144	$L_{pA} = 83 \text{ dB}$
	$L_{pCpeak} = 97 \text{ dB}$
	$L_{WA} = 96 \text{ dB}$

ATTENTION! The noise level when working may exceed 85 dB.

Wear ear protection!

Weight 4 kg

3. PRE-FABRICATION

The seam and the right angle flange, pre-fabricated with a roll forming machine, bending brake or a beading machine, are put together as shown on sketch N°1

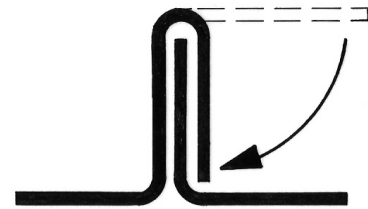

Sketch N°1

Attention: In order to make easier to start closing the seam with the machine the first couple of centimetres of the seam should be closed e.g. with a hammer.

BEFORE OPERATION:

Before starting to operate with the tool please check the following points:

1. Make sure that the **power supply voltage** is the same as the operating voltage indicated on the machine rating plate.
2. Sheet metal thickness of the seam lap (shall not exceed 1 mm, see technical data)
3. Required free space between the jaws:

Case 1: Z-seam and right angle flange have the same material thickness (material thickness t)

Required free space = $3 \times t$

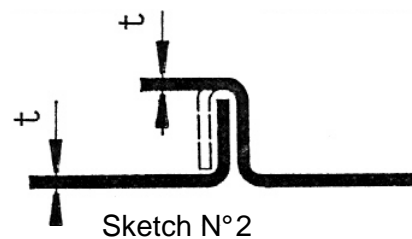

Sketch N°2

Case 2: Z-seam (material thickness t) is to be bent e.g. on a profile (material thickness s)

Required free space = $2 \times t + s$

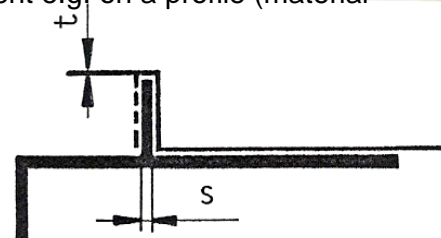

Sketch N°3

Attention: The maximum free space between the jaws is normally 3.5 mm.
Special construction on request.

4. Adjusting the free space between the jaws

- ◆ Insert the gauge in the required sheet metal thickness (3 x 0.5 mm; 3 x 0.75 mm or 3 x 1 mm) in the space between the jaws.
- ◆ Twist the eccentric [45] with a screw driver.

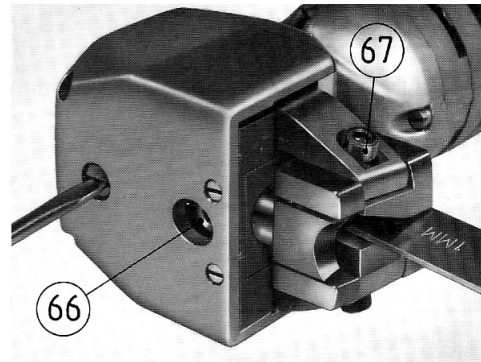

Photo N° 1

- A) The jaws touch the gauge and the eccentric may be easily twisted by 360°
 ⇒ Adjusting correct
- B) The jaws touch the gauge but the eccentric may not be twisted 360° without using extreme power.
 ⇒ Adjusting not correct
- Loosen screw [67] on working jaws
 - Move the jaws towards the working head, in order to obtain the required free space between the jaws
 - Tighten the screws [67]
 - Check once again with the gauge
- C) The jaws do not touch the gauge at all
 ⇒ Adjusting not correct
- Loosen the screws [67] on working jaws
 - Move the jaws away from the machine head (free space between the jaws decreases) in order to obtain the required free space between the jaws
 - Tighten the screws [67]
 - Check once again with the gauge

ATTENTION: Also with the gauge between the working jaws, it must be possible to twist the eccentric easily by 360°.

TIP: An easy way to control the required free space between the jaws is to close couple of centimetres of a seam with a hammer and then measure its total thickness. Through adjusting the free space between the jaws accordingly, it is guaranteed that the seam is closed tightly and that the tool is not overstressed unnecessarily.

4. Adjusting the hammer head

The left edge of the hammer head should be approximately 1 mm deeper than the front edge of the left working jaw.

- ◆ Loosen screw [66]
- ◆ Adjust the hammer head
- ◆ Tighten screw [66]

IMPORTANT! The screws have to be always tightened steadily after adjusting the tool. Otherwise the tool could be damaged when taking into operation.

OPERATION

1. CLOSING ON STRAIGHT PIECES

- ◆ For easier handling the machine head may be turned by 180°
 - Loosen screw [65]
 - Turn the handle into the desired position
 - Tighten screw [65]
- ◆ Insert the tool on the seam: The lap of the Z-seam shall always be on left side
- ◆ Lift the handle of the tool slightly in order to guide the lower edges of the working jaws parallel to the seam.
- ◆ Press the switch trigger – tool runs . To keep the tool running without holding fingers on the trigger – depress trigger and push switch locking button. To stop: depress trigger and release
- ◆ Move the tool rapidly forwards

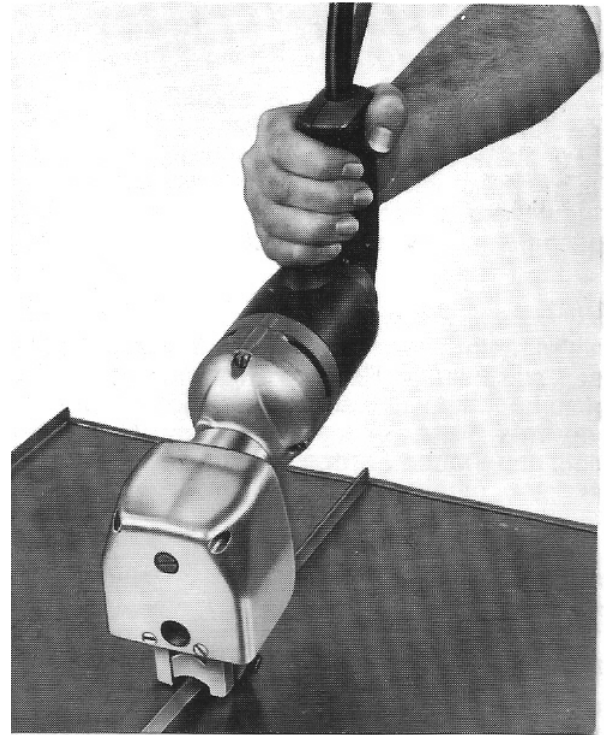

Photo N°2

2. CLOSING ON ROUND PIECES

- ◆ For ease of operation, especially when closing ducts with a small diameter, the handle should show downwards (see Photo N°3)
- ◆ For small diameters adjust the hammer foot [57] a little bit deeper
- ◆ Insert the tool on the seam and go on like on straight pieces

ATTENTION! Careful with working pieces where the material overlaps or shows a welding joint (risk of breakage).



Photo N°3

3. CLOSING OF SMALL SEAM HEIGHTS (3 - 6 mm)

The standard hammer head and the left working jaw are to be replaced with the optional parts for 3...6 mm seams:

- ◆ Remove screw [66] on hammer head and pull the hammer head out
- ◆ Insert the special hammer head and tighten screw [66]
- ◆ Replace the left working jaw with the optional jaw

Attention! Check the required free space between the working jaws.

- ◆ Go on as described above

ATTENTION: When closing a seam with a thin gauge metal sheet, the adjusting range of the working jaws sometimes does not guarantee a tight closing of the seam. In order to extend the adjusting range a thin steel shim should be inserted between the working jaws and the working jaw holders. After this adjust the free space between the jaws as described in II/3.

MAINTENANCE

The tool has to be handled carefully and protected against excessive dirt.

Always keep air venting slots clean!

If the tool is in continual use, annual inspection by an authorised service station is recommended.

Repairs must be performed by an authorised service station.

GUARANTEE

Products of WUKO Maschinenbau GMBH are warranted to be free from defects in material and workmanship for the valid period according to the national prescriptions (to be confirmed by invoice or other shipping documents).

This warranty applies only to products purchased new from the manufacturer or its authorised distributors. Of course, this warranty does not apply to products which have been abused, misused, modified or repaired without using genuine WUKO parts or repaired by someone other than the manufacturer or its authorised services representatives.

If a WUKO product proves defective in material or workmanship within the warranty period after purchase, return it to the manufacturer or your local WUKO dealer, transportation prepaid, enclosing your name and address, adequate proof of date of purchase and a short description of the defect. WUKO Maschinenbau GMBH will, at its option, repair or replace defective products free of charge. Repairs or replacement are warranted as described above for the remainder of the original warranty period. WUKO Maschinenbau GmbH's sole liability and your exclusive remedy under this warranty is limited to repair or replacement of the defective product.

This warranty is in lieu of and supersedes all other warranties or conditions, expressed or implied, and all other warranties whether for merchantability or fitness or otherwise are hereby disclaimed. Repair or replacement shall be the only liability of WUKO Maschinenbau GMBH under this warranty. No alteration, amendment or extensions of this warranty shall be effective unless authorized in writing by an officer of WUKO Maschinenbau GmbH.

Neither WUKO MASCHINENBAU nor any of its affiliates shall be liable for consequential, incidental or special damages or any other damages, costs or expenses incurred irrespective of how they occur. WUKO MASCHINENBAU's liability on any claim shall never exceed the purchase price of the product or part thereof which gives rise to the claim.



Do not dispose of power tools in household waste

According to the European Guide Lines 2002/96/EG for waste electric and electronic equipment and its implementation into national law, power tools that are no longer useable must be collected separately and recycled in an environmentally friendly manner.

EC Declaration of Conformity

We, the manufacturer

WUKO Maschinenbau GmbH
Dr. Maleta-Str. 1
A-4664 Oberweis
Tel. +43 7612 77500
Fax + 43 7612 77500 14



declare under our sole responsibility that this product,

WUKO Seam Closer 1003A
Fabrication Number:

is in conformity with the following standards or standardized documents:
MSV, BGBL. Nr. 306/1994, 89/392/EWG and 89/336/EWG;
EN 50144, EN 55014, EN 28662-1, EN 60555, HD 400, EN 292-1:1991,
EN 292-2:1991

Oberweis, March 2005
Place / Date

Pertti Hakala
Signature / Name

SPARE PARTS FOR THE HEAD OF THE WUKO SEAM CLOSER 1003A

Pos.	Pcs.	Description
45	1	eccentric shaft
46	1	housing baseplate
47	1	distance hoop
48	2	cam rings
49	1	working jaw holder, left
50	1	working jaw holder, right
51	2	bearing pins of working jaw holder
52	1	piston bearing
53	1	piston
54	1	bearing plate
55	1	working jaw, left
56	1	working jaw, right
57	1	hammer head
58	1	piston spring
59	1	working jaw spring

Pos.	Pcs.	Description
60	1	housing cap
61	1	grooved ball bearing
62	2	roller bearings
63	2	fixing pins
64	2	fixing pins
65	1	machine head screw
66	1	machine head fixing screw
67	2	working jaw fixing screws
68	2	distance hoop fixing screws
69	2	bearing plate fixing screws
70	2	housing plate fixing screws
71	2	housing cap fixing screws
72	1	gauge
73	1	allan key, size 5
74	1	allan key, size 6
75	2	screws

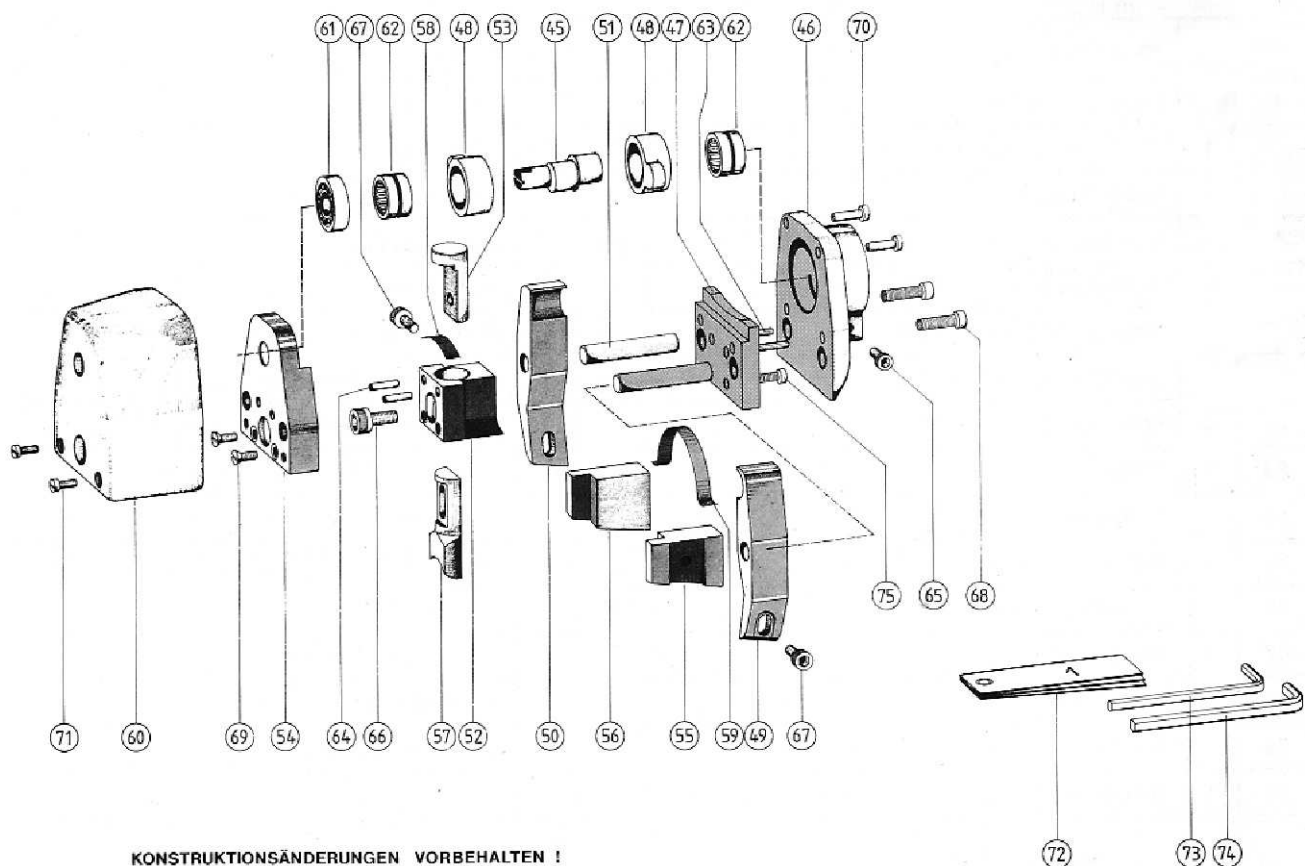

SPARE PARTS FOR THE ELECTRIC DRIVE OF THE WUKO SEAM CLOSER 1003A

Pos.	Pcs.	Description
2	1	Type plate
4	1	Connection cable
100	1	Housing
104	1	Handle cover
105	1	Magnet with winding
106	1	Armature compl.
107	1	Ventilator
108	1	Bearing
109	1	Washer
112	1	Rubber bushing
117	1	Cable
118	1	Cable
130	1	Ring collar
135	1	Switch
140	1	Capacitor
200	1	Bearing plate
204	1	Needle bearing
205	1	Felt washer

Pos.	Pcs.	Description
207	1	Cap
210	1	Spindle
211	1	Bearing
212	1	Sun wheel
213	3	Planet wheel
214	1	Ring gear
215	2	Washer
216	8	Ball
217	1	Pinion
218	15	Ball
219	1	Washer
220	1	Locking ring
222	1	Locking ring
431	2	Carbon brush
1000	1	Screw set
1200	1	Service set
1201	2	Carbon brush

